

REV.	REVISION RECORD	BY	DATE
0	ORIGIN	ZPJ	4.15.2026

CUSTOMER'S MODEL: NO MODEL  
END COVER COLOR: BLACK

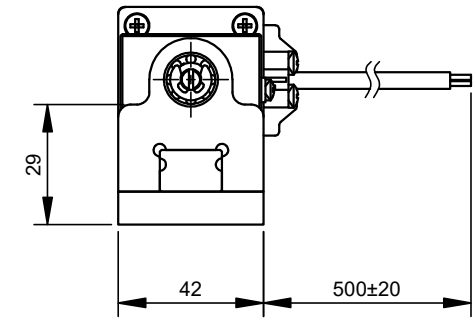
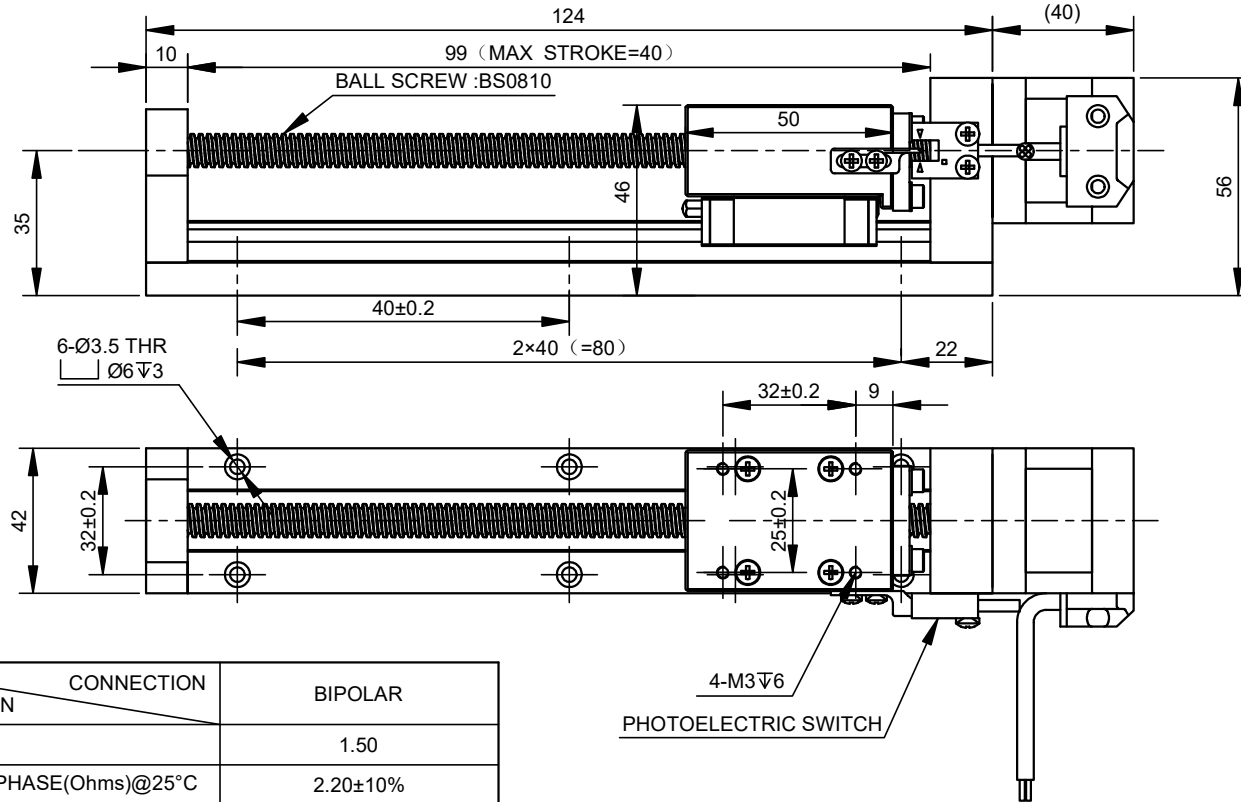

SPECIFICATION	CONNECTION	BIPOLAR
AMPS/PHASE		1.50
RESISTANCE/PHASE(Ohms)@25°C		2.20±10%
INDUCTANCE/PHASE(mH)@1KHz		4.60±20%
HOLDING TORQUE(Nm)[lb-in]		0.40[3.54]
MAXIMUM THRUST(N)		105
STEP ANGLE(°)		1.80
STEP ACCURACY(NON-ACCUM)		±5.00%
LEAD(mm)		10
LINEAR TRAVEL/STEP(mm)		0.05
RATED LOAD CAPACITY(N)		85
MAX SPEED(mm/s)		200
POSITION ACCURACY(mm)		±0.02
AMBIENT TEMPERATURE		-20°C~50°C[-4°F~122°F]
INSULATION CLASS		B 130°C[266°F]
TEMPERATURE RISE		MAX.80°C

COMMENT:  
1.TMBF 6000h OR MORE @ 24V/300RPM  
2.INSULATION RESISTANCE (NORMAL TEMPERATURE AND HUMIDITY): 100 Mohm  
3.DIELECTRIC STRENGTH 500VAC FOR 1MIN. (BETWEEN THE MOTOR COILS AND THE MOTOR CASE )

PHOTOELECTRIC SWITCH SEQUENCE		
PIN NO	BIPOLAR	LEADS
1	+5~24V	BRN
2	GND	BLU
3	SIGNAL LINE	BLK
4	N/A	WHT

MOTOR CONNECTION			
PIN NO	BIPOLAR	LEADS	WINDING
1	A+	RED	
2	A-	RED/WHT	
3	B+	GRN	
4	B-	GRN/WHT	

FULL STEP 2 PHASE-Ex.,WHEN FACING MOUNTING END (X)					CCW	CW	DIMENSIONS ARE IN MILLIMETERS. TOLERANCES AS BELOW: DECIMALS ANGLES X ±0.5 ±2° X.X ±0.25 X.XX ±0.13
STEP	A+	B+	A-	B-			
1	+	+	-	-			
2	-	+	+	-			
3	-	-	+	+			
4	+	-	-	+			



LINEAR ACTUATORS

LMD17S15B1B15-040

SIGNATURE		DATE
DRN	ZPJ	4.15.2026
APVD	MYX	4.15.2026