

| REV. | REVISION RECORD | BY | DATE |
|------|-----------------|-----|-----------|
| 0 | ORIGIN | LDJ | 4.15.2026 |

CUSTOMER'S MODEL: NO MODEL
 END COVER COLOR: BLACK

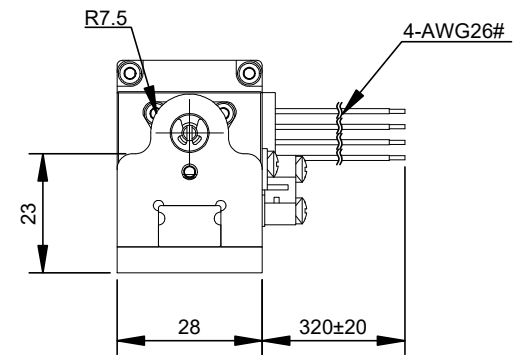
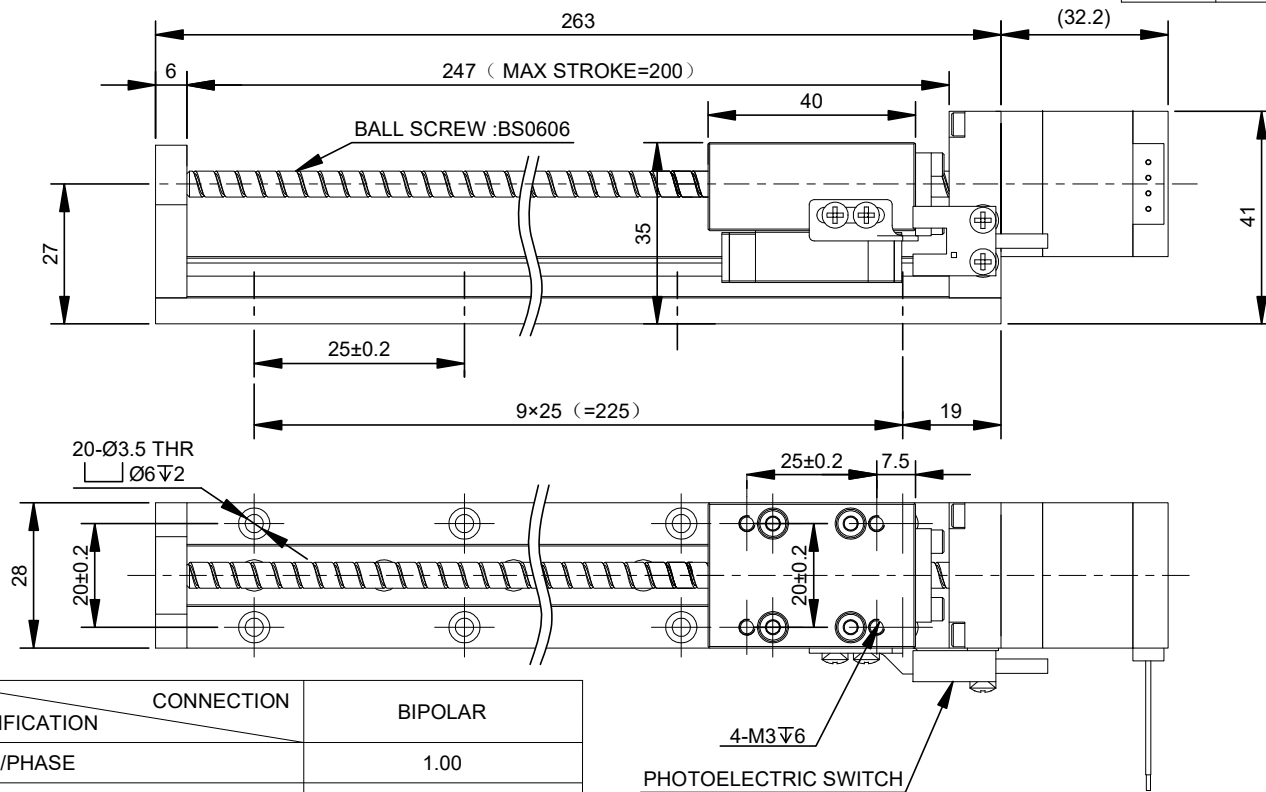

| PHOTOELECTRIC SWITCH SEQUENCE | | |
|-------------------------------|-------------|-------|
| PIN NO | BIPOLAR | LEADS |
| 1 | +5~24V | BRN |
| 2 | GND | BLU |
| 3 | SIGNAL LINE | BLK |
| 4 | N/A | WHT |

| SPECIFICATION | CONNECTION | BIPOLAR |
|-----------------------------|------------|------------------------|
| AMPS/PHASE | | 1.00 |
| RESISTANCE/PHASE(Ohms)@25°C | | 2.50±10% |
| INDUCTANCE/PHASE(mH)@1KHz | | 1.50±20% |
| HOLDING TORQUE(Nm)[lb-in] | | 0.05[0.44] |
| MAXIMUM THRUST(N) | | 18 |
| STEP ANGLE(°) | | 1.80 |
| STEP ACCURACY(NON-ACCUM) | | ±5.00% |
| LEAD(mm)[in] | | 6[0.2362] |
| LINEAR TRAVEL/STEP(mm)[in] | | 0.03[0.0011811] |
| RATED LOAD CAPACITY(N) | | 12 |
| MAX SPEED(mm/s) | | 90 |
| POSITION ACCURACY(mm) | | ±0.02 |
| AMBIENT TEMPERATURE | | -20°C~50°C[-4°F~122°F] |
| INSULATION CLASS | | B 130°C[266°F] |
| TEMPERATURE RISE | | MAX.80°C |

COMMENT:
 1.TMBF 6000h OR MORE @ 24V/300RPM
 2.INSULATION RESISTANCE
 (NORMAL TEMPERATURE AND HUMIDITY): 100 Mohm
 3.DIELECTRIC STRENGTH 500VAC FOR 1MIN.
 (BETWEEN THE MOTOR COILS AND THE MOTOR CASE)

| MOTOR CONNECTION | | | |
|------------------|---------|---------|---------|
| PIN NO | BIPOLAR | LEADS | WINDING |
| 1 | A+ | RED | |
| 2 | A- | RED/WHT | |
| 3 | B+ | GRN | |
| 4 | B- | GRN/WHT | |

| FULL STEP 2 PHASE-Ex.,WHEN FACING MOUNTING END (X) | | | | | CCW | CW | DIMENSIONS ARE IN MILLIMETERS. TOLERANCES AS BELOW: DECIMALS ANGLES X ±0.5 ±2° X.X ±0.25 X.XX ±0.13 |
|--|----|----|----|----|-----|----|--|
| STEP | A+ | B+ | A- | B- | | | |
| 1 | + | + | - | - | | | |
| 2 | - | + | + | - | | | |
| 3 | - | - | + | + | | | |
| 4 | + | - | - | + | | | |

STEPPERONLINE®

LINEAR ACTUATORS

LMD11S13BUM10-200

THIS DOCUMENT SHALL NOT BE REPRODUCED NOR SHALL THE INFORMATION CONTAINED HEREIN BE USED BY OR DISCLOSED TO OTHERS UNLESS EXPRESSLY AUTHORIZED IN BY WRITING STEPPERONLINE.

| SIGNATURE | | DATE |
|-----------|-----|-----------|
| DRN | LDJ | 4.15.2026 |
| APVD | LJ | 4.15.2026 |